



THE NEW STANDARD IN MINING MOBILITY



Catalogue

100% ELECTRIC MINING
VEHICLES

Electric Cruiser & HLX

100 % ELECTRIC MINING VEHICLES

Tembo e-LV B.V.
info@temboelv.com
+31 497 76 02 01



354M

EMERGENCY 4x4

BF Goodrich
Mud-Terrain T/A



What is an Tembo e-LV

BENEFITS OF ELECTRIC LIGHT VEHICLES

IMPROVED WORKING CONDITIONS

- ✓ Zero emissions
- ✓ Less noise
- ✓ Less vehicle heat

COST SAVINGS

- ✓ Low maintenance cost
- ✓ Low operational cost
- ✓ Lower ventilation cost
- ✓ No need of expensive fuel infrastructure
- ✓ Less downtime

MORE COMFORTABLE DRIVING EXPERIENCE

- ✓ Smooth acceleration
- ✓ Accelerates gradually
- ✓ Better weight distribution
- ✓ No engine noise

The Tembo e-LV is a Toyota Land Cruiser or Hilux converted into a 100% electric vehicle.

The diesel engine and gearbox are replaced with an electric motor fitted with a newly designed Tembo 1:3 reduction gearbox. The rest of the vehicle is kept original.



The Toyota Land Cruiser 70 Series & Toyota Hilux are the most commonly used light vehicles in mining worldwide. The heavy-duty frame and powertrain have proven to survive in these rough environments and the basic design makes the Land Cruiser & Hilux the ideal base for special build conversions needed for the different trades inside the mines. However, the standard Land Cruisers & Hilux with diesel engines cannot meet future emission standards

It is the first zero emissions lv that withstands challenging mining operations, helps improve working conditions and reduces the need for ventilation.

Tembo e-LV uses high-quality components from the automotive industry. All parameters of the engine such as maximum speed and torque can be customised to a setting suitable for your requirements. Precise fleet management gives clients complete control over the vehicle, its usage and maintenance status.

The engine and gearbox of a Tembo e-LV have been replaced with the electric unit, which is powered by batteries mounted under the hood and where the fuel tank would normally be. The smoothness of the electric engine reduces strain on the vehicle, also enhancing the driving experience.

The Tembo e-LV conversion brings up-to-date comfort and zero emissions to the light mining vehicle while retaining reliability.

Models:

- e-LV76 5drs Station Wagon
- e-LV78 3drs Hardtop
- e-LV79 single & double cab
- e-LV71 2drs short wheelbase
- e-LV Hilux single, Xtra & double cab
- LHD or RHD (Australia & South Africa only)





Improved working conditions

BENEFITS OF ELECTRIC LIGHT VEHICLES

IMPROVED WORKING CONDITIONS

- ✓ Zero emissions
- ✓ Less noise
- ✓ Less vehicle heat
- ✓ Employer branding
- ✓ Governmental preference

Zero emissions

Health & safety and clean air are a big part of the challenges faced in underground mining and especially the diesel particulate matter exposes the underground miners to serious health risks and for this it is obvious that the days are just about over for the diesel-powered Land Cruiser & Hilux.



Less noise generation

Everyone who has been underground knows how difficult it is to just talk to each other. The noise from the vehicle itself and from ventilation can be decreased drastically when there are no emissions.

Less vehicle heat

Combustion engines have an approximate 40% efficiency of energy use and generate a lot of heat instead, where the e-motor has an efficiency over 90%.

Employer branding

Working with modern technology in a clean environment makes working in the mining industry a lot more appealing for potential new employees.

Governmental preference

Regulatory bodies are gradually starting to favour mines that commit to an all-electric underground environment, resulting in approvals for permits that would otherwise be denied, along with a faster permitting process, both of which are potentially game-changing for mining companies around the world.





Cost savings

BENEFITS OF ELECTRIC LIGHT VEHICLES

COST SAVINGS

- ✓ Low maintenance cost
- ✓ Low operational cost
- ✓ Lower ventilation cost
- ✓ No need of expensive fuel infrastructure
- ✓ Less downtime



Low maintenance cost

Because of the regenerative braking using the e-motor, the brakes can be used for a much longer time. No servicing on air-, oil- or fuel filters and gearboxes or oil changes. By replacing the clutch and engine the maintenance is minimized.

Less downtime

The higher reliability of the electrical components and the reduced number of components guarantee that less maintenance is required and therefore less downtime will occur.

Low operational cost

The biggest cost savings can be made on energy, while the energy needed to provide clean and fresh air into the mine and to ventilate the exhaust gasses and heat out of the mine will be considerably lower when only electrical powered equipment is used. On average the cost of ventilation of an underground mine is 20-40% of all overhead cost.

For calculating the ventilation requirements of an underground mine usually the amount of BHP/kW of diesel-powered equipment is used, so less diesel vehicles means less ventilation needed.

An additional advantage is that because electricity is a lot cheaper than diesel this results in an immediate decrease of fuel cost.

No need of expensive and hazardous fuel infrastructure

The transport and infrastructure for fossil fuels to and in a mine is very costly and potentially dangerous. With electric vehicles you can use the electric infrastructure which is already there for light and ventilation and the risk is very low.

The deeper the mine, the more savings can be made.





Comfortable driving experience

BENEFITS OF ELECTRIC LIGHT VEHICLES

MORE COMFORTABLE DRIVING EXPERIENCE

- ✓ Smooth acceleration
- ✓ Accelerates gradually
- ✓ Better weight distribution
- ✓ No engine noise

Smooth acceleration

There is no gearbox so no gear changing and therefore there is no jerking of the vehicle when accelerating

The EVCU is set to gradually increase the power to the drivetrain to provide a smooth ride. This gives less stress on the driveline.



Better weight distribution

By dividing the battery capacity over the front and the rear of the vehicle, the weight distribution improves and prevents bouncing of the rear of the vehicle which is a common issue when driving an empty pick-up vehicle.

No engine-noise

An electric engine makes almost no sound, making this a huge benefit compared to big diesel engines, not only for miners but also less noise-pollution for the surrounding areas of mine sites.



Certified batteries

The battery system is designed with the highest level of safety.

Heavy duty and water- and dustproof battery housing

Operational environment temperatures of battery and e-motor may vary from -20 up to +70 degrees Celsius with water cooling and heating for subzero areas.



Optional fire suppression system

This system uses water in combination with high pressure and a small amount of foam additive. All three components of the chain reaction that causes a fire – heat, oxygen and fuel – are attacked simultaneously.

Speed limiter

The speed limit of the vehicle can be set by the use of the software that is accessible via the instrument panel in the dashboard (password protected).

Onboard diagnostics

The instrument panel offers several fleet management options to keep the (electric) fleet in optimal condition.

Emergency failsafe brake system (optional)

Wet brake systems available as emergency brakes which can become active when a door is opened while driving, the E-stop button is pressed or when the engine key is turned off. This system ensures that the vehicle cannot roll away unexpectedly (uncontrolled vehicle movement) – a feature that provides an unprecedented level of safety for vehicle operators and site personnel. These brakes reduce vehicle operating costs, improve brake reliability and significantly enhance vehicle safety.

Instrument panel

Custom designed instrument panel contains the following extra features:

- Time in operation
- Distance driven
- Service indicator set to workhours
- kWh used or regenerating
- Temperature of battery & E-motor
- Multiple main screens (km/h and/or kWh)
- Charging status/current in kW
- Customised logo's & background





Measurements

ELECTRIC CRUISER

Model: e-LV79 Single Cab

Part nr: TB3500

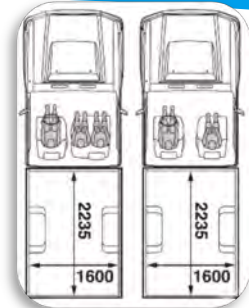
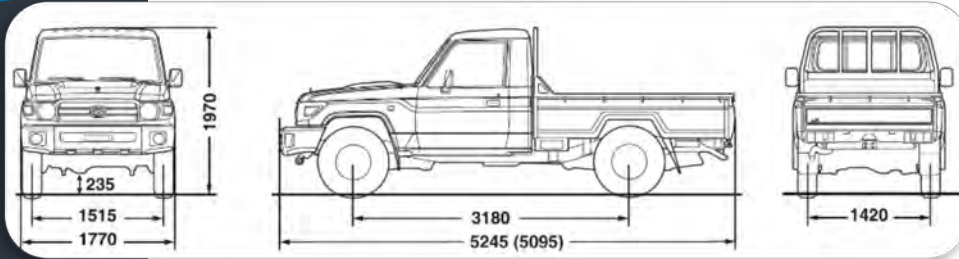

Minimal turn radius	7,2 meters
Suspension Front/Rear	Rigid axle coil springs/rigid axle, semi-elliptic leaf springs
Gross vehicle weight	3200 kg
Kerb weight	2195 kg
Payload	1060 kg
Tire size	Mud terrain 235/85R16 120/116Q
Axles	2
Dimensions (mm)	
• Length	5245
• Width	1770
• Height	1970
• Wheelbase	3180
• Ground Clearance	235
Seats	2/3

ELECTRIC CRUISER

Model: e-LV79 Double Cab

Part nr: TB3501

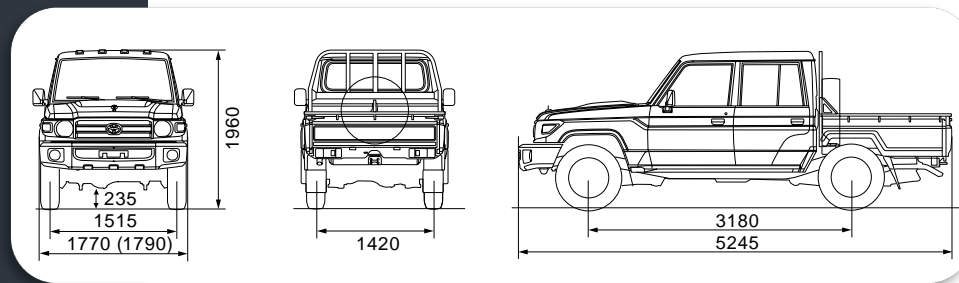

Minimal turn radius	7,2 meters
Suspension Front/Rear	Rigid axle coil springs/rigid axle, semi-elliptic leaf springs
Gross vehicle weight	3200 kg
Kerb weight	2290 kg
Payload	920 kg
Tire size	Mud terrain 235/85R16 120/116Q
Axles	2
Dimensions (mm)	
• Length	5245
• Width	1770
• Height	1970
• Wheelbase	3180
• Ground Clearance	235
Seats	5/6



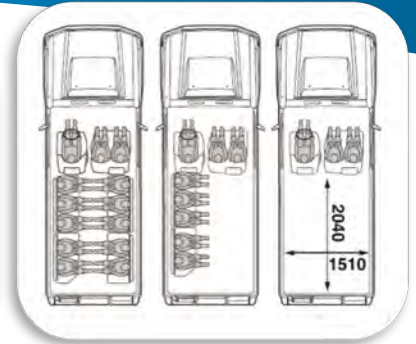
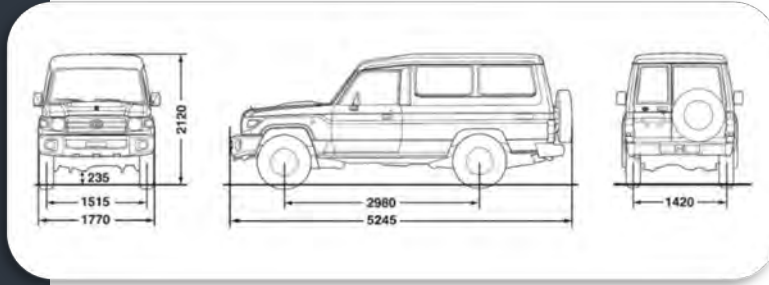

Minimal turn radius	6,8 meters
Suspension Front/Rear	Rigid axle coil springs/rigid axle, semi-elliptic leaf springs
Gross vehicle weight	3200 kg
Kerb weight	2300 kg
Payload	970 kg
Tire size	Mud terrain 235/85R16 120/116Q
Axles	2
Dimensions (mm)	
• Length	5245
• Width	1770
• Height	1970
• Wheelbase	2980
• Ground Clearance	235
Seats	3-13

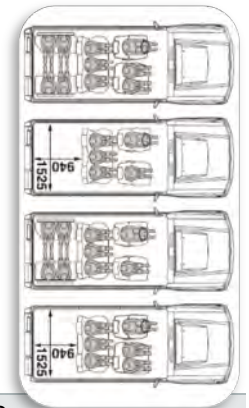
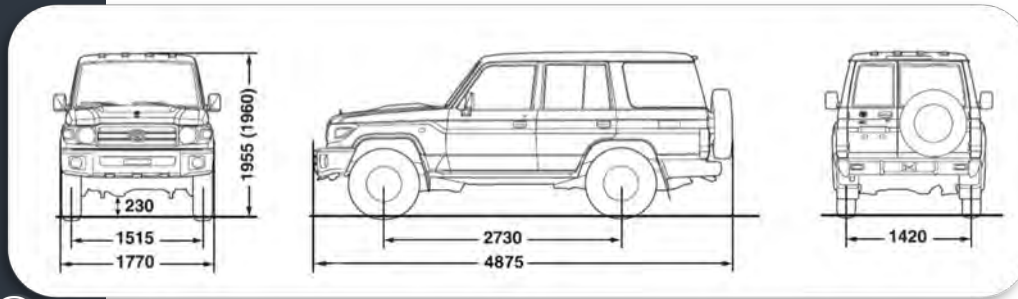

Minimal turn radius	6,3 meters
Suspension Front/Rear	Rigid axle coil springs/rigid axle, semi-elliptic leaf springs
Gross vehicle weight	3060 kg
Kerb weight	2235 kg
Payload	815 kg
Tire size	Mud terrain 235/85R16 120/116Q
Axles	2
Dimensions (mm)	
• Length	4875
• Width	1770
• Height	1955
• Wheelbase	2730
• Ground Clearance	230
Seats	5/6

ELECTRIC CRUISER

Model: e-LV71

Part nr: TB3506

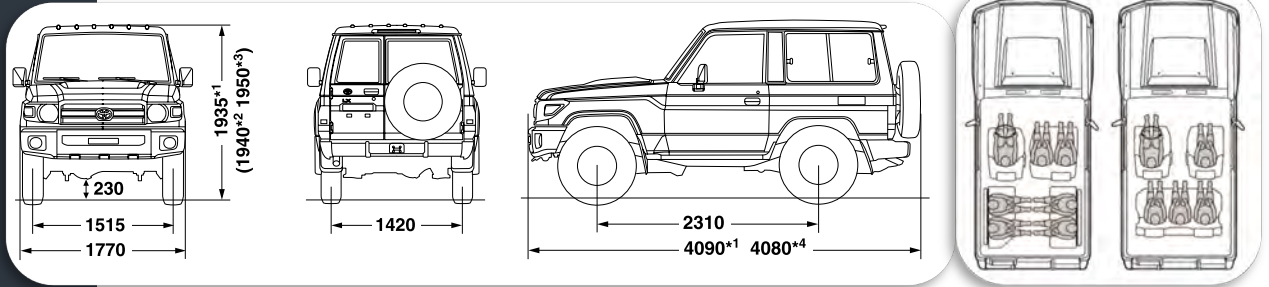

Minimal turn radius	5,5 meters
Suspension Front/Rear	Rigid axle coil springs/rigid axle, semi-elliptic leaf springs
Gross vehicle weight	2600 kg
Kerb weight	1880 kg
Payload	815 kg
Tire size	Mud terrain 235/85R16 120/116Q
Axles	2
Dimensions (mm)	
• Length	4875
• Width	1770
• Height	1955
• Wheelbase	2730
• Ground Clearance	230
Seats	5/6

ELECTRIC HLX

Model: HLX DC

Part nr: TB3504



Minimal turn radius	6,1 meters
Suspension Front/Rear	Fr: Double Wishbone - Rr: Leaf Spring
Gross vehicle weight	2910 kg
Kerb weight	1995-2075 kg
Tire size	Mud terrain 245/75R16 120/116Q
Axles	2
Dimensions (mm)	
• Length	5330
• Width	1815
• Height	1815
• Wheelbase	3085
• Ground Clearance	310
Seats	5



Electric HLX 6x6

ELECTRIC HLX

- Payload increased from 1000 to 3000 kg
- Replaced chassis which is 10% heavier and 30% stiffer than OEM
- Suitable for heavy loads with self levelling air-suspension system
- Additional 1230mm chassis length before overhang allowance increases load area
- Improved overall traction from 6 driven wheels
- Reduced ground pressure and improved vehicle mobility with 2 rear axles
- Transfer box: equipped with a 'torsen-style' differential to deliver drive to the rear axles with two prop-shafts, thereby splitting the torque loading.
- Braking system: The front of the vehicle is fitted with a larger 6-piston caliper, discs and high-performance pads, centre and rear axle is OEM, with three axle ABS function.



Key technical specifications 6x6

Homologated Weights:

Kerb weight: 2500Kg	Front axle capacity: 1620kg
Payload: 3000Kg	Middle axle capacity: 2100kg
GVW: 5500Kg	Rear axle capacity: 2100kg

Trailer weights:

Braked trailer: 3500kg	Gross train weight: 8100kg
------------------------	----------------------------



Dimensions:

Vehicle Length: 6300mm (as conversion platform)	Wheelbase: 3300mm (centre) & 4300mm (rear)
Min Vehicle Length: 5652mm (min rear overhang)	Frame Extension: 1200mm
Max Vehicle Length: 7536mm (max rear overhang)	Load bed Length: 2672mm (min) & 4552mm (max)





Turnkey solutions

We offer turnkey solutions to provide the perfect vehicle for your purpose.





Mining accessories

Accessories from simple safety improvements to drivetrain and bodywork replacements.

HEAVY DUTY VEHICLE SOLUTIONS

- SAFETY IMPROVEMENTS
- DRIVETRAIN UPGRADES
- BODYWORK REPLACEMENTS
- ROLLOVER PROTECTION STRUCTURE (ROPS)
- BUMPERS
- FLEET MANAGEMENT

OTHER ACCESSORIES

- SPEED LIMITERS
- ON/OFF SWITCH SAFETY LOCKS
- WINCHES
- SUSPENSION KITS

1. Heavy duty bumper



6. Seat covers



11. Stalk lamp



2. Rollcage



7. First aid kit/bracket

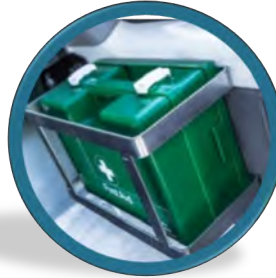

12. Worklamps



3. Load barrier



8. Fire extinguisher/bracket



13. Rotating light bar



4. Roll bar



9. Fire suppression system



14. Buggy whips



5. Personal cell protection



10. Drawer systems



15. Stickers



CUSTOM SOLUTIONS

These accessories are examples of what is possible. Please ask us if you have any specific demands or needs.



16. BF Goodrich mud/terrain tires



21. Load tray drop sides



17. Wet brakes



22. Load tray coating



18. Loose wheel nut indicator



23. CCTV



19. CouplerTec electronic rust proofing



24. Kevlar personnel protection

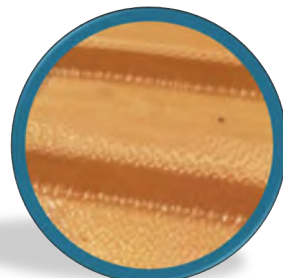

20. Reversing alarm



25. Under body protection



